



PLOW MOUNT KIT

FOR HONDA PIONEER

P/N 34-1010

ASSEMBLY / OWNERS MANUAL

Application

PLOW PUSH FRAME NO. 34-0000 or 34-0070

Before you begin, please read these instructions and check to be sure all parts and tools are accounted for. The following instructions contain details required to install and service the contents of this kit.

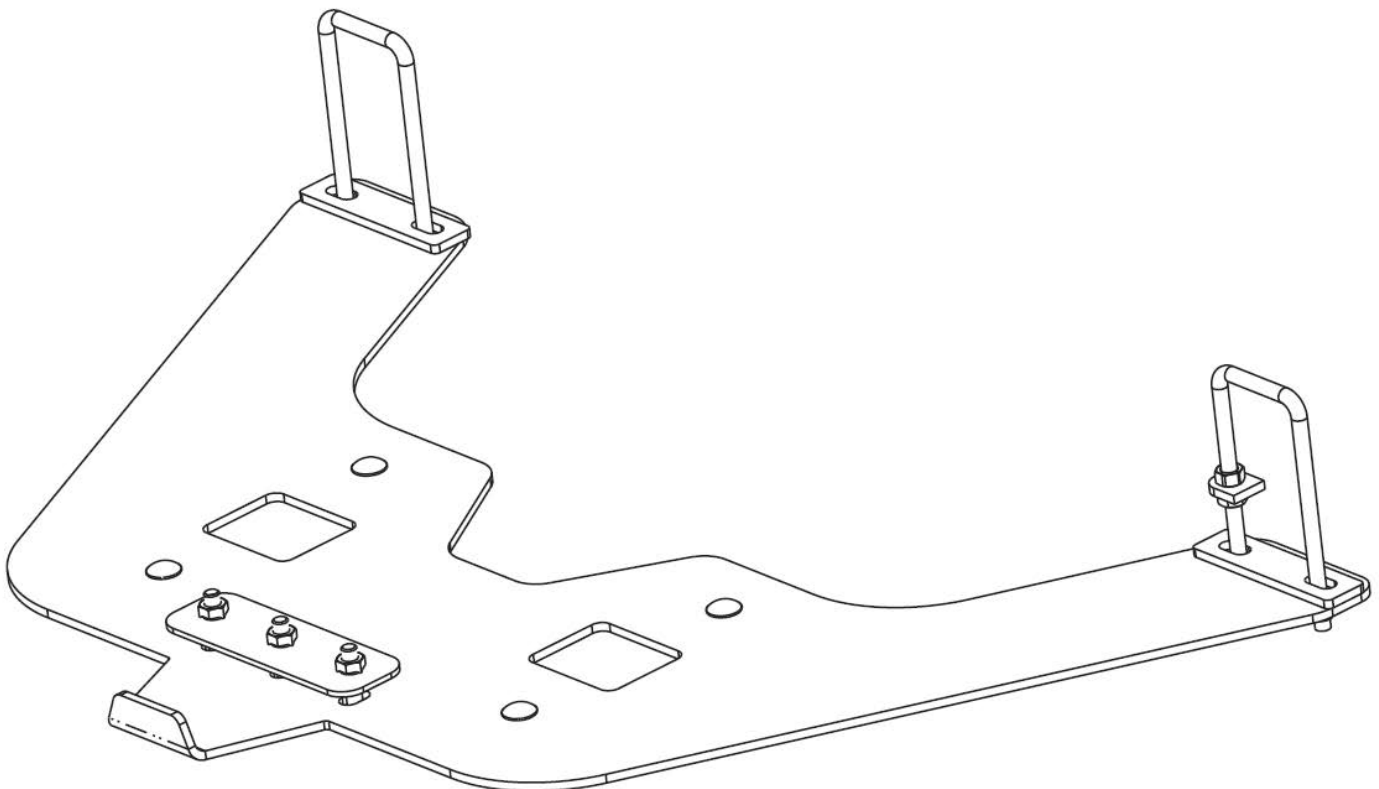

OPERATING INSTRUCTIONS

Congratulations! You've just purchased the most durable plow component in the industry. Kolpin plow components work great for summer or winter plowing. With proper care and maintenance, your Kolpin plow system will last for years to come!

NOTICE

Plow operation requires additional components for operation: *Kolpin Plow Blade, Kolpin Plow Push Frame, High Rise Plow Push Frame, Winch Kit* *

**These components may be specific to your vehicle.*

Please read and understand all assembly instructions, notices and warnings before assembling and operating your Kolpin plow system.

Follow these guidelines to ensure satisfactory operation:

- Read this manual and your ATV/ UTV operators manual before use.
- Periodically check for wear and tightness of all fasteners. Replace or re-torque fasteners as necessary.
- Before first use, set plow in the furthest right or left angled position to check for interference with the vehicle.
- Operate with extreme caution on slopes and rough terrain. Be familiar with the area before you plow.
- Be aware of immovable objects that could be hidden in the area you are plowing.
- To avoid damage when pushing snow into a pile, reverse direction before raising the plow blade.
- Do not ram the plow blade into piles of snow.
- For best results, set the suspension preload of your ATV/ UTV to the stiffest setting.
- To reduce steering effort and increase mobility, set the air pressure of your tires to the maximum pressure specification.
- The plow skids are adjustable. General skid setting is even with the plow wear bar bottom edge, higher settings reduce the chance of rocks and gravel from being collected.
- To increase traction during plow operation, operators can try: Securing weight to the ATV/ UTV for additional tire downforce, reducing tire air pressure, or installing tire chains.

SAFETY INFORMATION

Our plow systems were designed with your safety in mind. Please read and understand all Cautions, Notices and Warnings in this manual before you begin. In order to protect you and your ATV/UTV, certain parts of the plow system and/or hardware are designed to fail when the equipment is over-stressed.



DANGER



TO AVOID SERIOUS INJURY OR DEATH:

1. **DO NOT EXCEED 5 MPH (8 KMH) WITH BLADE INSTALLED.**
2. **OPERATE WITH EXTREME CAUTION ON SLOPES, STEEP GRADES, AND ROUGH TERRAIN.**
3. **ALLOW NO RIDERS ON BLADE OR ATV/UTV WHILE MOVING OR STATIONARY.**
4. **KEEP BYSTANDERS AWAY FROM THE BLADE OR ATV/UTV WHILE MOVING OR STATIONARY.**
5. **WHEN PUSHING HEAVY MATERIAL, DIRECTION CONTROL MAY BECOME DIFFICULT.**
6. **BEFORE ADJUSTING BLADE: STOP ATV/UTV ENGINE; SET AND LOCK BRAKES; RAISE AND LOCK BLADE IN UP POSITION. DO NOT ATTEMPT TO RAISE BLADE BY HAND; USE THE LIFT MECHANISM ONLY.**
7. **LOWER BLADE TO DOWN POSITION WHEN BLADE AND ATV/UTV ARE NOT IN USE.**
8. **READ BLADE'S INSTRUCTION SHEETS AND ATV/UTV OWNER MANUAL.**

Kit Contents:

Item	Qty	Part Description	Part Number
1	1	Pioneer Mount Plate	-
2	2	Square U-Bolts, Zinc Plated	-
3	2	U-bolt Spacer	-
4	8	Flange Locknut, Zinc Plated, M8-1.25	-
5	1	Brake Line Protector	-
6	4	Carriage Bolt, Zinc Plated, M8-1.25 x 25mm LG	-
7	1	Nut Plate	-
8	3	Hex Bolt, Zinc Plated, M8-1.25 x 35mm LG	-
9	3	Flat Washer, Zinc Plated, M8	-
10	2	Hex Nut, Zinc Plated, M8-1.25	-
11	1	Instruction Guide (not shown)	-

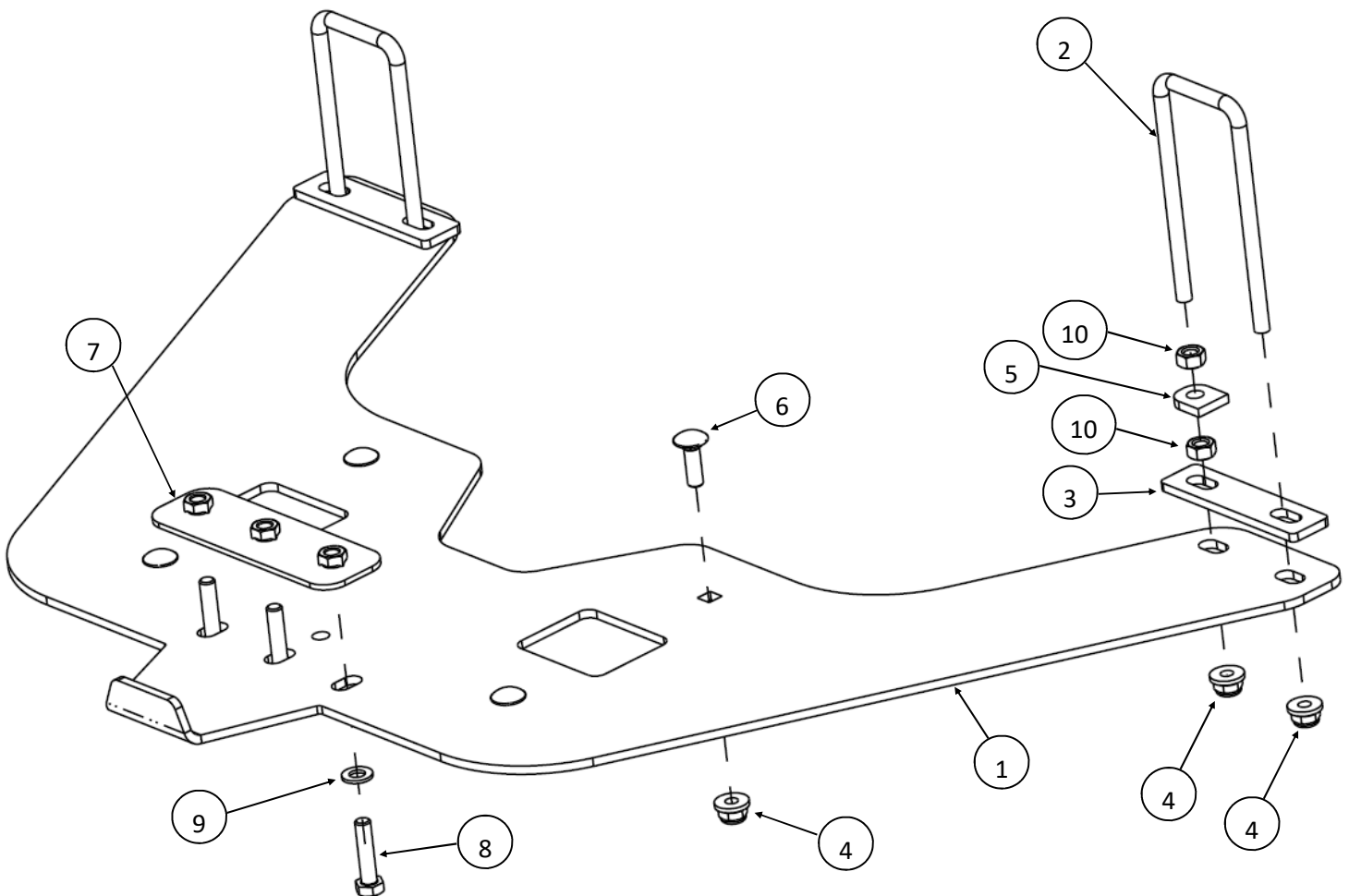

BEFORE YOU BEGIN:

- Your Kolpin accessory is exclusively designed for your vehicle
- Please read and understand all instructions
- Verify all parts and tools are accounted for
- To ensure a satisfactory installation, follow all steps correctly and in the sequence described
- Keep these instructions for future reference or for informational requests
- To facilitate installation, make sure that your vehicle is clean and free of debris
- All directions referring to right and left are when the rider is sitting on the machine
- The plastic skid plate will need to be modified to be reinstalled on the vehicle.

TOOLS REQUIRED:

- 10mm Socket
- 13mm Wrench and 13mm Socket
- Drill or cutting tools for plastic

APPROXIMATE ASSEMBLY TIME: 30 minutes

Note: Removal and modification of the plastic skid plate is recommended.

Note: Additional time may be required to accommodate other installed accessories.

Note: If any hardware is missing, do not return to the store. Call us to help, Toll Free 1-877-956-5746.

SPARE KITS		Hardware kit P/N 34-0012
Item	Description	
2	Square U-Bolts, 131mm	4x
6	Carriage Bolt, Zinc Plated, M8-1.25 x 25mm LG	4x
10	Serrated Nut, Zinc Plated, M8-1.25	2x
4	Flange Locknut, Zinc Plated, M8-1.25	12x
-	Hex Bolt, Zinc Plated, M8-1.25 35mm LG	3x
-	Flat Washer, Zinc Plated, M8	3x

Spare Kit Notes:

- Spare kits may contain extra hardware that is used for other mount kits. Extra hardware can be discarded.
- U-bolts supplied in spare kits may be longer than original and may need to be cut to size.

Installation Prep:

1. From under the vehicle, insert the Nut Plate (item #7) into position in the rearward 3 holes in the bottom of the vehicle front chassis skidplate as shown. (See illustrations 1-1 and 1-2).
2. Temporarily install the Pioneer Mount Plate (item #1) to the vehicle. Assemble the Pioneer Mount Plate using the Hex Bolts (item #8), Flat Washers (item #9), and the Nut Plate (item #7) as shown. Do not tighten at this time. (See illustration 1-3).
3. Use the Pioneer Mount Plate (item #1) as a pattern to mark the two rear mounting holes into the plastic skid plate as shown. (See illustrations 1-3 and 1-4).

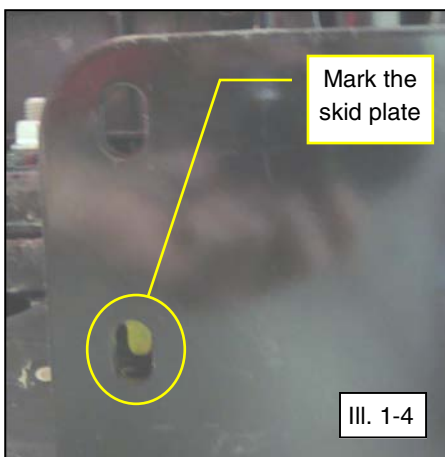
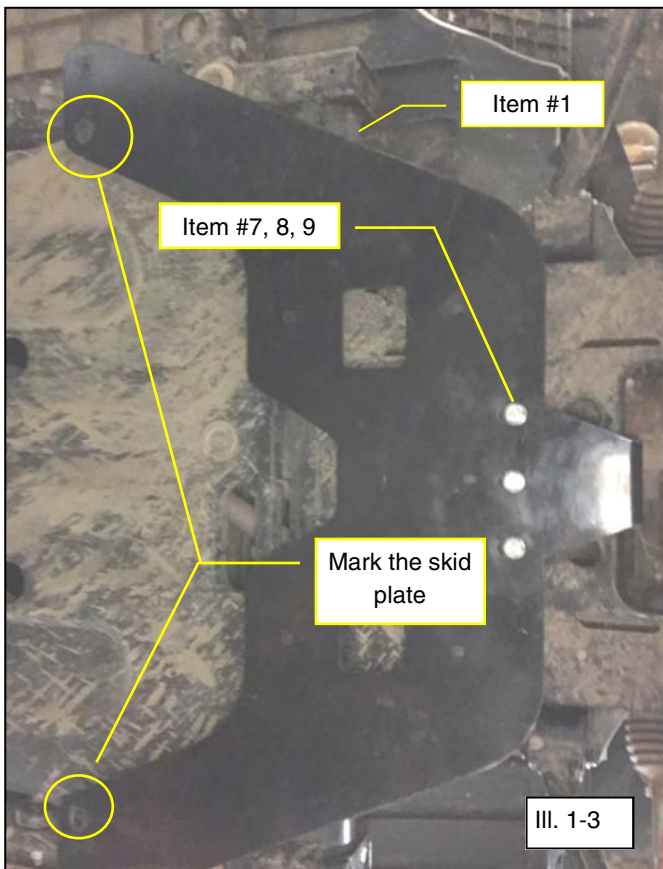
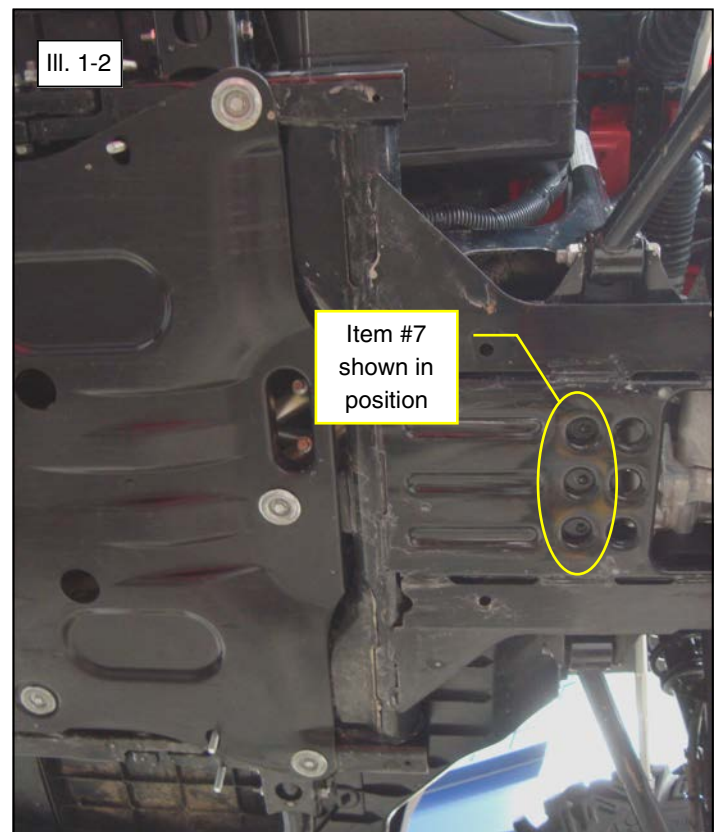
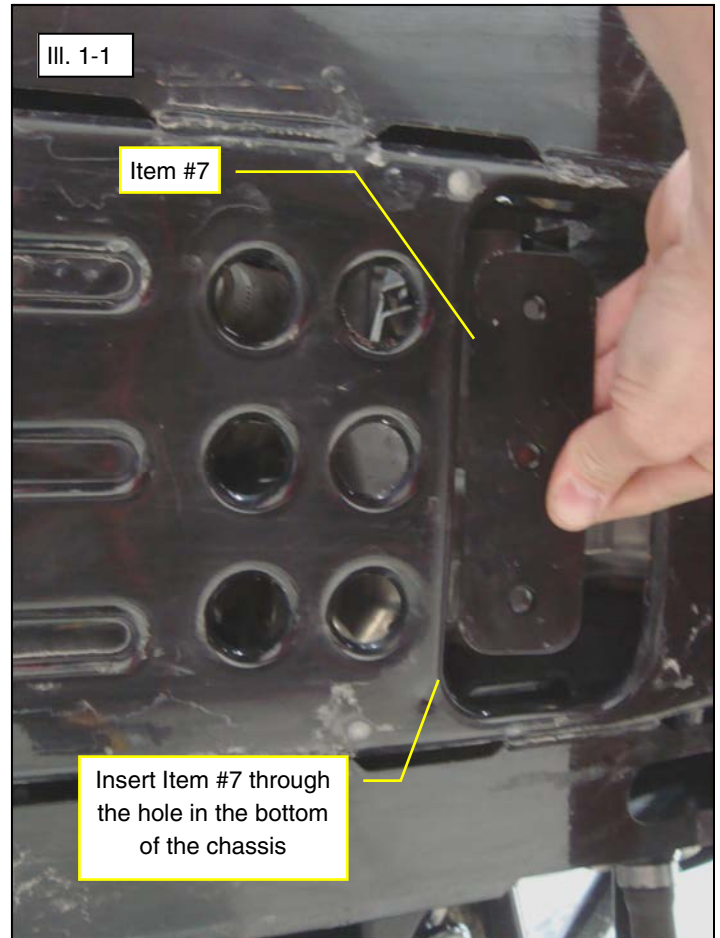

Installation Prep (Continued):

4. Remove the Pioneer Mount Plate (item #1) from the vehicle by removing the Hex Bolts (item #8) and the Flat Washers (item #9). (See illustration 1-3).
5. Detach the middle plastic skid plate from the vehicle by removing the OEM hardware and save for re-install later. (See illustrations 1-5 and 1-6).
6. Drill holes through the skid plate at locations marked. Use a 3/8" to 1/2" bit to create an oversized hole that will allow some relief when installing hardware. **Note, a high speed cutting tool (like a Dremel) with a cutting bit will also work.** (See illustrations 1-5 and 1-6).
7. From inside the vehicle cab, remove the OEM hardware and save for re-install later. This will allow the floorboard to flex upwards for clearance to fit u-bolts (item #2) between the floorboard and the frame tube as shown. (See illustrations 1-7 and 1-8).

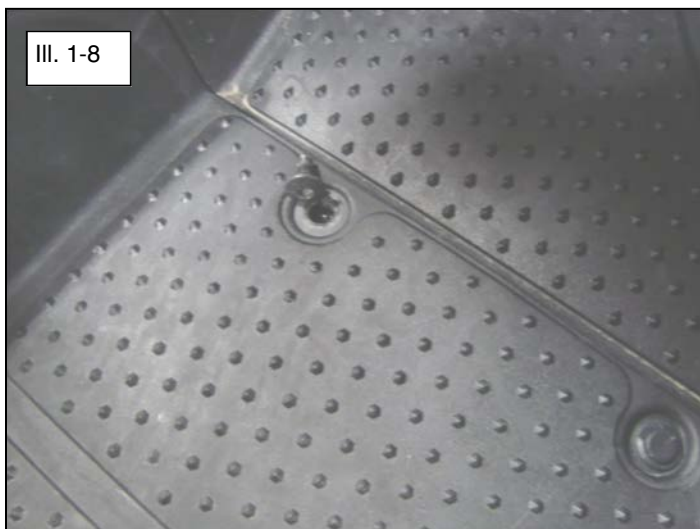
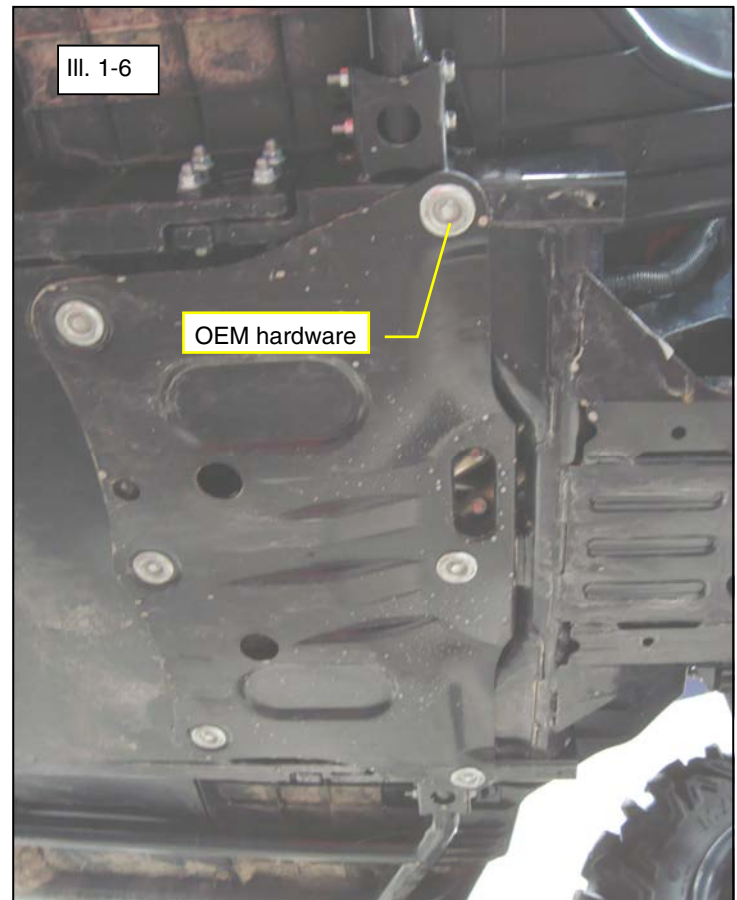
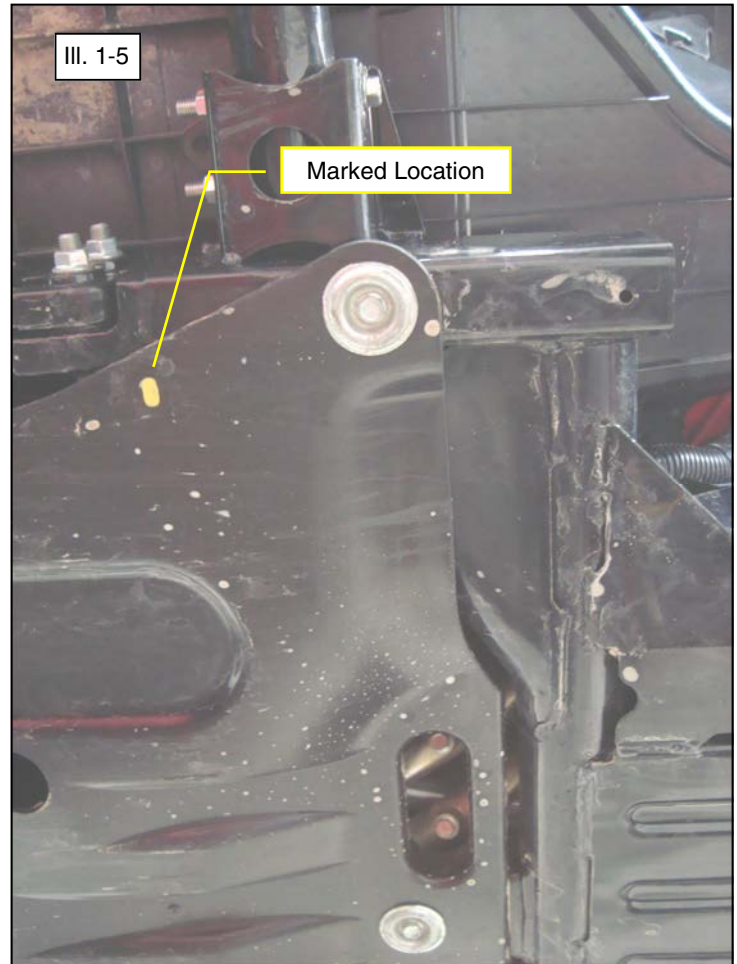

Mount Plate Installation:

8. From under the vehicle, position the U-bolts (item #2) around the middle frame tubes as shown. (See illustrations 2-1 and 2-2). **Note, a pry bar will provide extra leverage when flexing the plastic floorboard upwards to gain access.**
9. Re-install the plastic skid plate onto the vehicle with the OEM hardware and position the u-bolts thru the drilled out sections as shown. (See illustration 2-3).
10. **The Brake Line Protector spacer is required for installation onto the left u-bolt. Thread the first serrated nut, item #10, onto the u-bolt. Then insert the brake line protector, item #5, onto the u-bolt and fasten with second serrated nut. (See illustrations 2-4 and 2-5).**

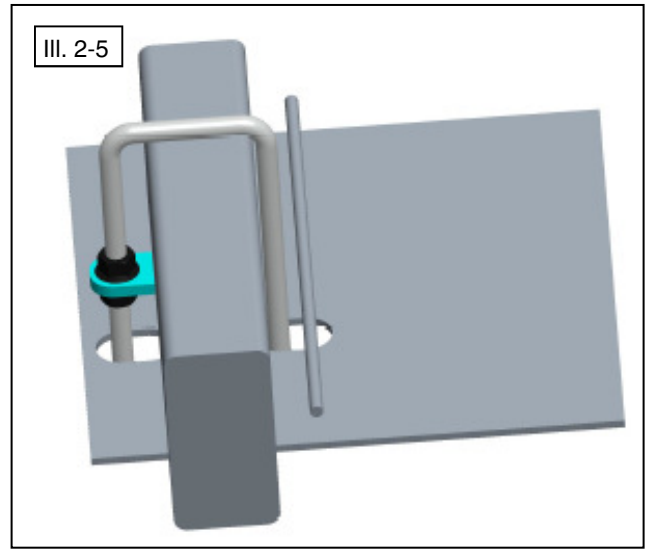
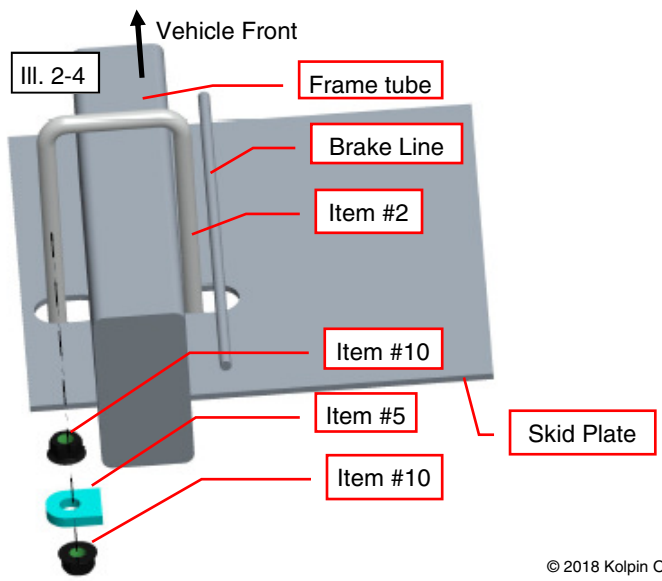
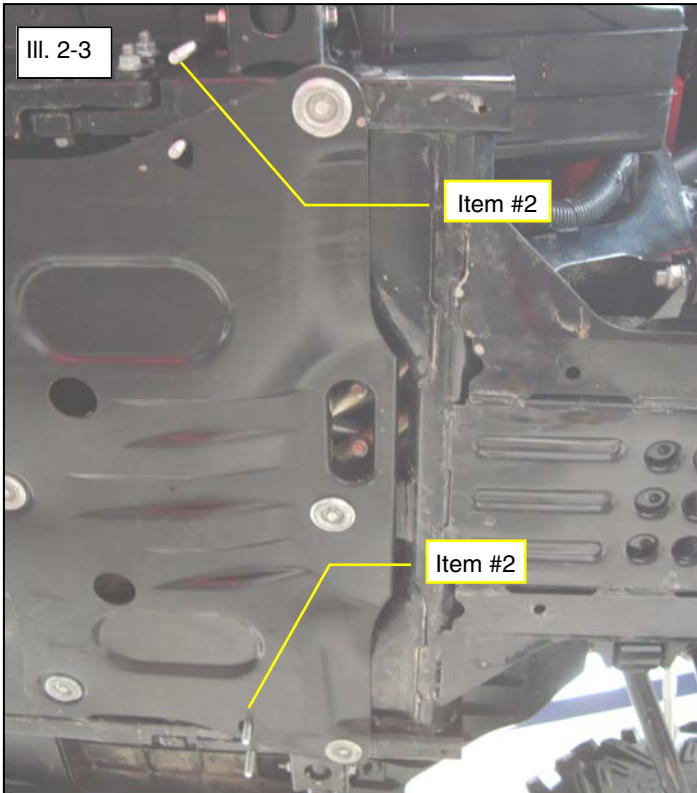
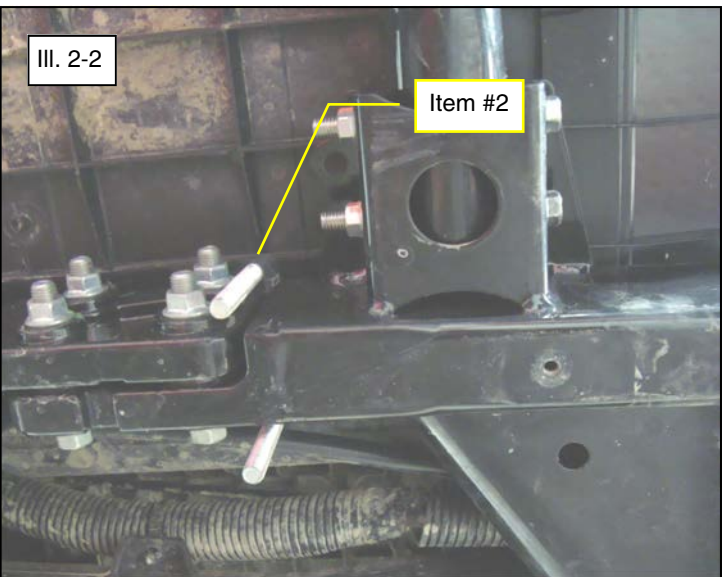
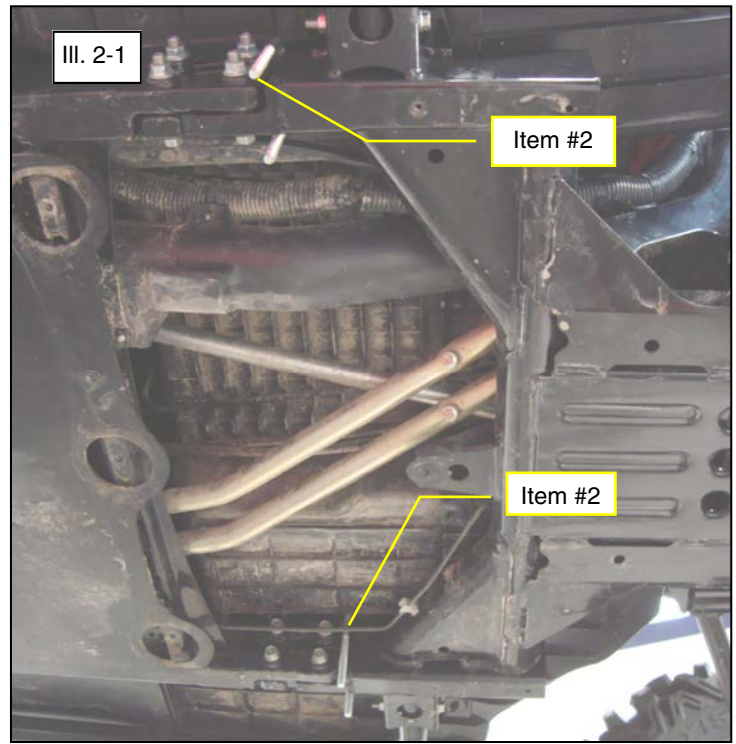

Mount Plate Installation (cont'd):

10. Place the U-bolt Spacer (item #3) onto the u-bolts. The spacer will fit in between the plastic skid plate and the Pioneer Mount Plate (item #1) as shown. (See illustration 2-6).
11. Install the Pioneer Mount Plate (item #1) onto the vehicle. The u-bolts will fit thru holes in the plate as shown. Fasten the u-bolts with the M8 locknuts, Item #4. Do not tighten at this step. (See illustration 2-7).
12. Insert the M8 carriage bolts (item #6) thru the plate as shown. (See illustration 2-7).
13. Assemble the M8 Hex Bolts (item #8) and the M8 Flat Washers (item #9) thru the mounting plate (item #1) into the Nut Plate (item #7). Tighten M8 hardware to specification. (See illustration 2-7).

 = T
8MM FASTENER TORQUE: 17 ft. lbs. (23 Nm)

14. Tighten the M8 locknuts (item #4) for securing the u-bolts (item #2). Use caution to not overtighten u-bolts. The excess threads can be trimmed, but leave 3-4 threads exposed past the locknut. (See illustration 2-7).
15. From inside the vehicle cab, re-install the hardware previously removed for securing the floorboards.
16. The universal mount plate, not included in this kit, will be attached to the Pioneer mount plate as shown. The M8 carriage bolts (item #6) will fasten the universal plate with the M8 locknuts (item #4). Tighten to M8 specification. (See illustration 2-8).

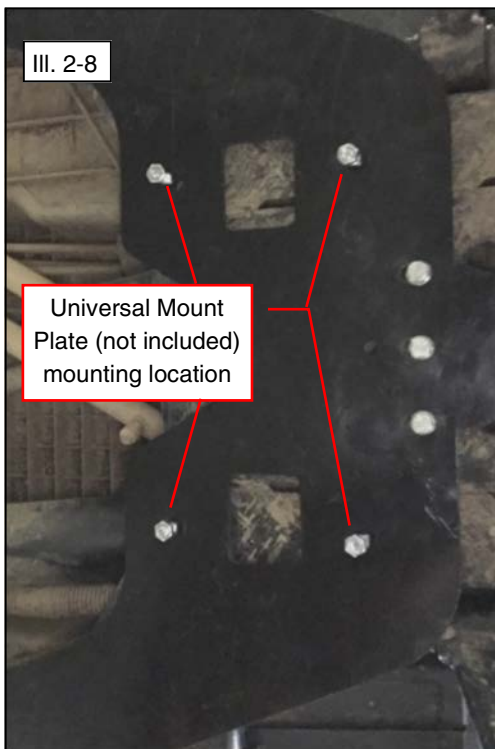
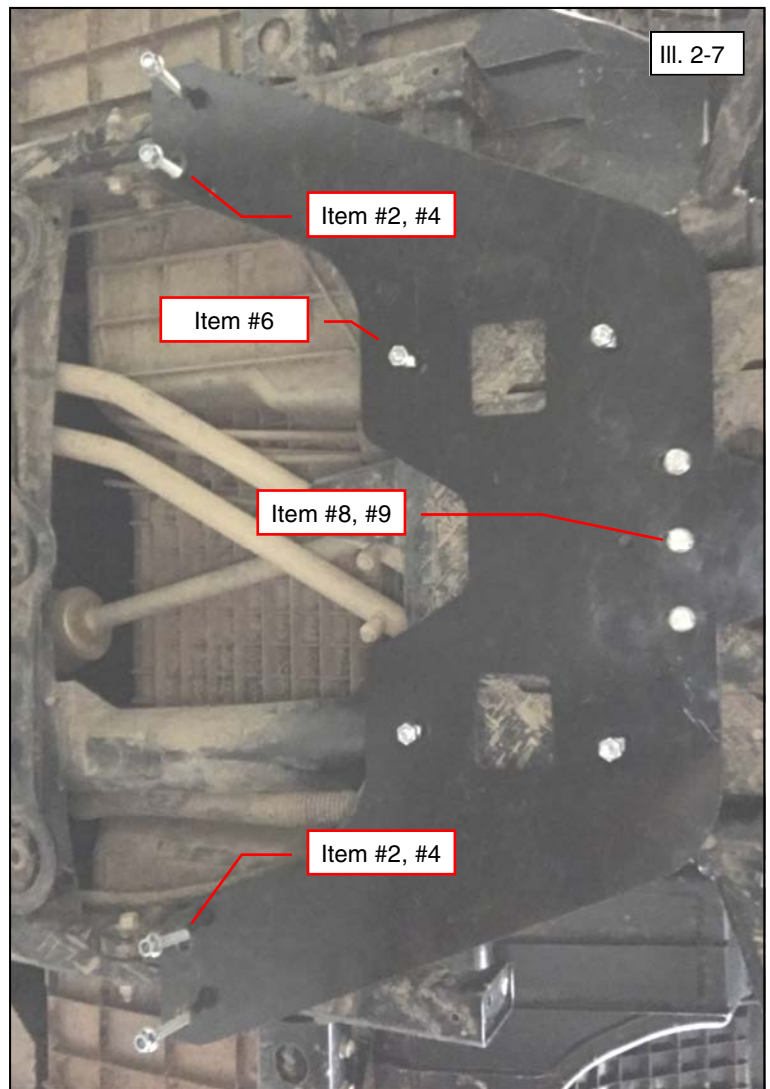
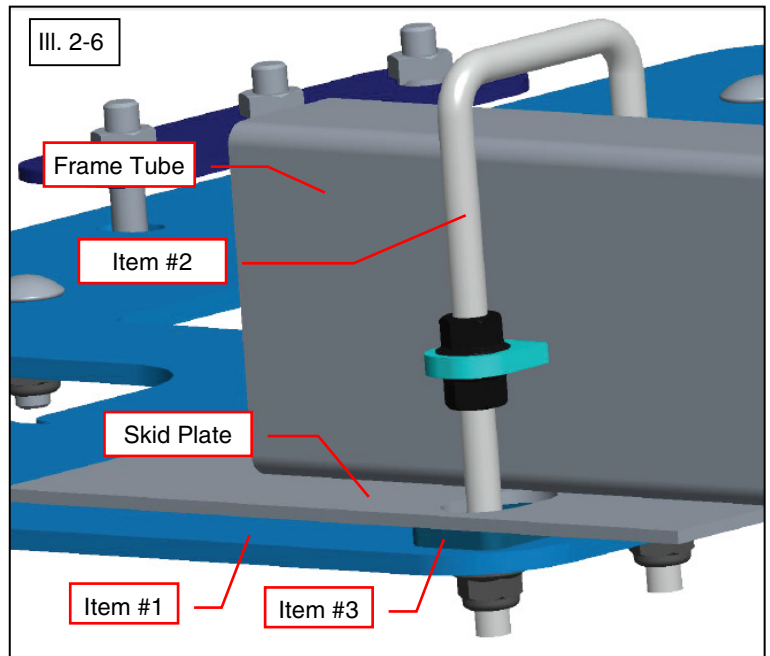



One Year Limited Warranty

For the period of one (1) year from the purchase date, Kolpin will replace for the original purchaser, free of charge, any part or parts found upon examination by Kolpin to be defective in material, workmanship, or both.

All transportation costs incurred submitting product to Kolpin for warranty consideration must be borne by the purchaser. If Kolpin determines that the product must be returned to the factory for credit, please call 1-877-956-5746 for a Return Merchandise Authorization (RMA) number and shipping instructions.

This warranty does not apply to parts that have been damaged by accident, alteration, abuse, improper maintenance, normal wear, or other causes beyond the manufacturer's control. In order to protect you and your ATV, certain parts of the plow system and/or hardware are designed to fail when the equipment is over-stressed. Parts that are lost due to loosening and improper maintenance are not covered under warranty. This warranty does not cover removal or reinstallation labor fees of the plow system and related components.

Peripheral products such as engines, electric motors, and actuators may carry an original manufacturer's warranty. Most hardware is general in nature and is easily obtained locally. Be sure to replace with minimum metric class 8.8 specification.

Kolpin Outdoors, Inc.

Telephone: (763)-478-5800

Toll Free: (877)-956-5746

Fax Number: (800)-245-7569

www.kolpin.com

Email: customerservice@kolpin.com